

## 22-29GHz Ultra-Wideband CMOS Pulse Generator for Collision Avoidance Short Range Vehicular Radar Sensors

Ahmet Oncu, B.B.M. Wasanthamala Badalawa, Tong Wang and Minoru Fujishima  
 School of Frontier Sciences  
 The University of Tokyo  
 Kashiwa, Japan  
 fujishima@axcel.k.u-tokyo.ac.jp

**Abstract** – The pseudo millimeter wave 22-29GHz ultra-wideband (UWB) is attractive for the applications in short-range (SR) automotive radar sensors in order to contribute to significant reduction of traffic fatalities. Although CMOS is suitable for the short-range radar since processing units can be implemented in the same chip with the UWB front-end building block, it is difficult to operate CMOS pulse generators at such a high frequency. To realize the pseudo-millimeter-wave band using CMOS, we have proposed a new pulse generator consisting of a series of delay cells and edge combiners with waveform shaping. As a result of measurement using 90nm CMOS technology, 1Gbps pulses are successfully generated with a power consumption of 1.4mW at a supply voltage of 0.9V. This result will be the key technology for a one-chip SR cost effective radar sensors.

### I Introduction

In 2002, the federal communication community (FCC) has established regulations for (UWB) vehicular radar systems in the 22 to 29GHz band with a maximum output power of  $-41.3\text{dBm/MHz}$ . Although 22-29GHz SR radar sensor systems have already been demonstrated, due to their inefficiency in terms of cost, they are not accepted by the automotive market for widespread use. For the effective public benefit only cost-effective radar sensor solutions are efficacious [1]. In conventional pulse-radar systems, a pulse-train output is generated by controlling a continuous-wave (CW) input using a pulse-width control switch [2], where the output pulse envelope has a rectangular shape. The power spectrum of the rectangular pulse results in a sinc ( $\sin(x)/x$ ) function, which inefficiently utilizes the FCC UWB transmission mask for short pulses. Additionally, using this method, it is necessary to turn on the oscillator throughout the data communication process, resulting in large power consumption. Furthermore, since the pulse generators mentioned above are realized using SiGe integrated circuits [1] or discrete components [2, 3], 22-29GHz pulse generator using CMOS is still challenging.

The amount of the discrete components and using various technologies in the single SR radar system increase the total cost. To reduce the cost and the power consumption, direct pulse generation without using an oscillator is suitable as adopted in impulse radio (IR) communication in the 3.1-10.6GHz UWB band. It has attractive characteristics of low cost and low power since it can be fabricated using digital CMOS technologies. In this work, the CMOS pulse generator circuit in Fig. 1 has been designed and implemented instead of a CW oscillator and a pulse-width control switch. The CMOS pulse generator circuit generates

pulses with a pseudo-raised-cosine (PRC) envelope having a better output spectrum with lower power consumption than those with the rectangular envelope.

### II. CMOS 22-29GHz Band Pulse Generator

The circuit topology of the pulse generator is shown in Fig. 2. It consists of two main circuits, delay-cell chain and edge combiners. Here, the rising edge of the input signal is passed through the delay-cell chain by contributing delays to form short pulses whose period equal to the half of the carrier period. Thereafter, the pulses are combined to create a complete waveform. To realize pseudo-millimeter wave frequencies using this technique, the pulse width should be narrowed, which is realized by making the rising and falling slopes steep. Since both slopes are proportional to the load capacitance in delay nodes, the load capacitances of the inverters in delay cells are equalized by merging a delay cell and a monopulse generator.

The monopulse generator consists of a delay cell and an edge combiner as shown in Fig. 2, where the delay cell is composed of two CMOS inverters and the edge combiner is composed of two NMOSFETs. Because of the faster switching capability, only NMOS transistors are used at the edge combiner circuit. By modulating the size of the edge combiners through the chain, a four level PRC pulse is obtained. The center frequency and the pulse width can be controlled by a delay-locked loop although it is not implemented in this version. Note that even though the delay-locked loop cannot reduce the jitter caused by the inverters, this jitter may not be a concern because there is no adjacent channel in frequency-domain in this application.

### III. Measurement Results

Fig. 3 shows a chip micrograph of the proposed pulse generator fabricated by 90nm CMOS technology. The time-domain response of the proposed pulse generator with a 100MHz input at a 0.91V supply voltage is shown in Fig. 4. The measurements were performed without any external filters at the output. As shown in Fig. 4, 14 pulses with a 39.2psec width have been realized using 14 monopulse generators.

The envelope of the pulse train follows the pseudo raised cosine as expected in simulation, although the baseline of the 14 pulses varies since load impedance is fixed to  $50\ \Omega$  while the driving current generated by the edge combiners changes. This pulse shape is maintained up to a high input data rate of 1Gbps at 0.91V supply voltage. The

frequency-domain response at an input frequency of 20MHz is shown in Fig. 5(a), where the FCC spectrum mask is fulfilled. Since the measurement limitations, the spectrum below 27GHz can be shown in Fig. 5(a), whole spectrum shape is also shown in Fig. 5(b) by adjusting the center frequency down to 22GHz. Finally, the performance of fabricated chip is compared with that of the conventional work [3] in Table I.

IV. Conclusions

A UWB pulse generator for the SR radar application in the 22-29GHz band was successfully fabricated using 90nm CMOS process. The power consumption is 1.4mW for an input bit rate of 1Gbps with a 0.91V supply voltage. Power consumption is proportional to the input bit rate down to 10Mbps, which corresponds to 2.8pJ per pulse and 1.4pJ per bit for an OOK modulation. The proposed pulse generator will open up a new application for the UWB SR radar sensor system with low power and low cost.

Table I. Performance summary of the fabricated chip and the conventional work.

	This work	[3]
Technology	90nm CMOS	0.25μm SiGe BiCMOS
Frequency Band	22-29GHz	15-27GHz
Modulation	OOK	FM-CW
Supply Voltage	0.91V	3.3V
Max. Input Data Rate	1 Gbps	2 Gbps
Power Consumption	1.4 mW @ 1Gbps	168mW @ 2Gbps
Core Size	90μm × 15μm	800μm × 660μm

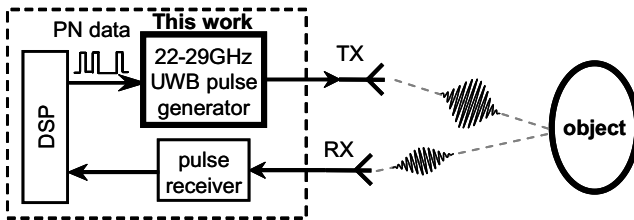

Fig. 1. Block diagram of CMOS SR radar system.

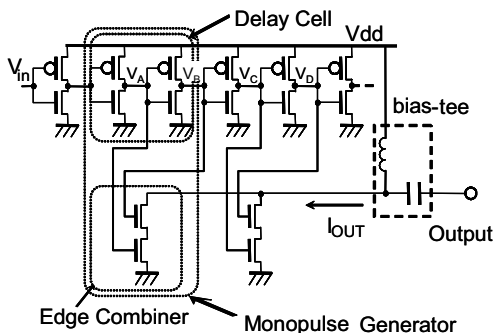

Fig. 2. Circuit topology of the pulse generator.

Acknowledgements

The VLSI chip in this study has been fabricated through the chip fabrication program of the VLSI Design and Education Center (VDEC), the University of Tokyo.

References

- [1] G. Rollmann, P. Knoll, M. Mekhaieil, V.Schmid and H.L. Blöcher, "Short Range Radar (SRR) System for Automotive Applications," IEEE- MTT/AP German Newsletter, vol. 8, no.1, pp. 4-8, 2004.
- [2] I. Gresham, A. Jenkins, R. Egri, C. Eswarappa, N. Kinayman, N. Jain, R. Anderson, F. Kolak, R. Wohler, S. Bawell, J. Bennett and J. Lanteri, "Ultra-wideband radar sensors for short-range vehicular applications," IEEE Transactions on Theory and Techniques, vol. 52, no. 9, pp2105-2122, 2004.
- [3] H. Veenstra, E. Heijden and D. Goor, "15-27 GHz pseudo-noise UWB transmitter for short-range automotive radar in a production SiGe technology," Proceedings of ESSCIRC, pp.275-278, 2005.

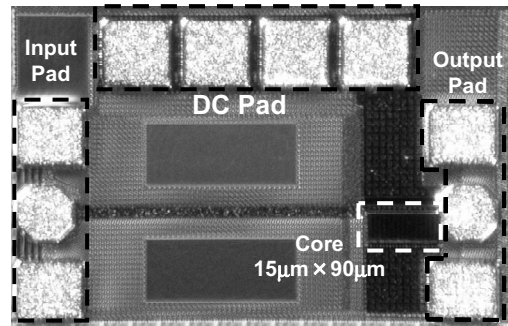

Fig. 3. Micrograph of the 22-29GHz CMOS pulse generator UWB SR radar sensor.

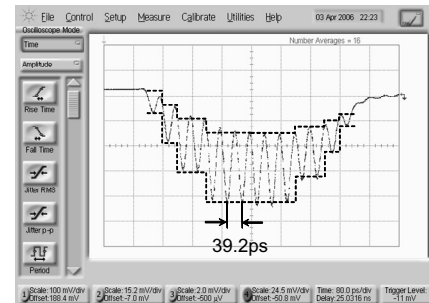

Fig. 4. Time-domain response of the pulse generator.

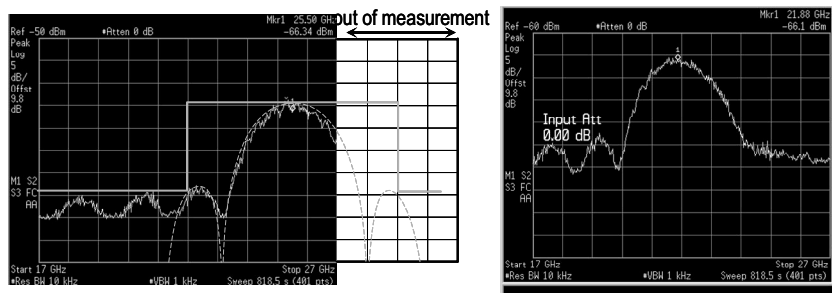

Fig. 5. Output spectrum of a pulse generator with the center frequencies of (a) 25.5GHz and (b) 22GHz. Due to measurement limitations, the spectrum up to 27GHz is measured. Dotted lines show the calculation results with PRC pulses.